

C. BECHSTEIN

Academy A 228



Welcome to the exquisite German grand and upright piano manufactory.

”

Piano music should
only be written
for the Bechstein.

Claude Debussy

**Ever since 1853,
C. Bechstein has been
handcrafting the finest
masterpieces of
German piano tradition,
the gold standard for the
most sophisticated ears
and discerning fingers.**

The grand pianos in the C. Bechstein Academy line possess a wonderfully illustrious and elegant yet also fresh and impulsive sound.

Like the Concert line, Academy grand pianos are built to uncompromisingly high standards of quality by experienced masters at the C. Bechstein manufactory in Seiffhennersdorf.

With the warm, coveted C. Bechstein sound, Academy grand pianos are suitable for a wide range of music genres. This makes them the perfect instrument for any professional pianist, ambitious musician or music lover, as well as conservatories and universities.

A warm, intimate and colorful sound

High controllability from any position of the key movement, quick repetition

C. Bechstein hammer heads with mahogany mouldings

Fine-grained soundboard made from European mountain spruce

Inner rim made from cross-laminated sheets of beech veneer

Compatible with Bluetooth MIDI (C. Bechstein Connect)



— IRMA GIGANI —

Academy A 228

Top quality – Handmade in Germany

The A 228 is the largest grand piano in the C. Bechstein Academy line. In the best C. Bechstein tradition, it impresses with its enormous dynamic range and sublime, fundamental and colorful sound. Thanks to the traditional C. Bechstein action, its sound can be easily and precisely modulated and shaped. Designed and manufactured in the C. Bechstein manufactory in Germany.

Dimensions & weight	229.5 × 159 cm 418 kg 7' 6" × 5' 3" 922 Lbs
Designs	Black, white; other finishes and veneers available on request
Soundboard	Selected European mountain spruce
Action & hammerheads	Original C. Bechstein components; Developed and produced by C. Bechstein
Pedals	Piano (Una Corda), Sostenuto, Forte (Dampers)
Keys	Man-made white key tops with a pleasant grip & ebony sharps
Music stand	tiltable in 8 angles
Lid prop	2-piece, fully or half open lid

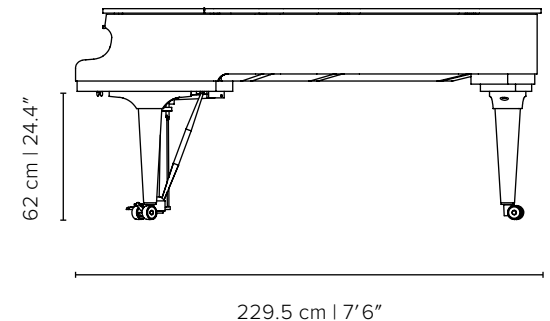
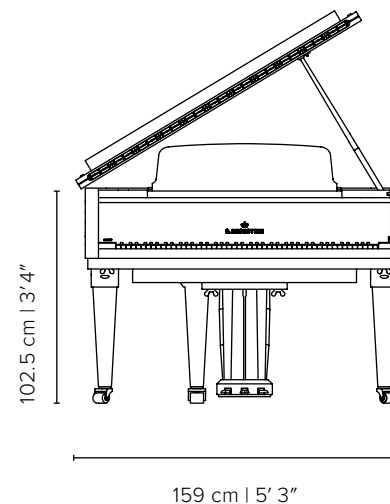

[→ Learn more about the model](#)

Academy A 228 | Acoustic assembly

C. BECHSTEIN RESILIENT SOUND SYSTEM

Carefully selected, cleverly balanced components as well as manufacturing techniques developed and carefully guarded by C. Bechstein guarantee sound-supporting tension, optimal tuning stability and exceptional longevity.

INNER AND OUTER RIM

The inner rim constitutes the soundboard frame and, like the outer rim, is a single piece of **cross-laminated 1mm thick layers of European beech veneer**. Pretensioned by the method of gluing and balanced by the resting period, the inner rim helps prevent the loss of energy from the soundboard in the acoustic assembly.

BACK FRAME

The robust, triple-laminated tapered pine braces with **continuous external layers** are affixed to the inner rim by strong **dowel joints**. ① The belly rail is made of glued beech and pine with a **soundboard support rail made from solid beech**.

PINBLOCK

Block with three solid layers of American hard maple, outer layers made from cross-laminated sheets of beech veneer. High proportion of solid wood for excellent and even tunability and tuning stability

TUNING PINS

Quality tuning pins made from nickle-plated steel, **6.9 mm × 64 mm**. Balanced torque, low torsion, excellent tunability and tuning stability, **with tuning pin bushings**.

Back frame using the example of C. Bechstein Academy A 190





– ARTISANS – C. BECHSTEIN MANUFACTORY SEIFENHERSDORF –

Academy A 228 | Acoustic assembly

CAST-IRON FRAME

The cast-iron frame has the stability needed to withstand the enormous string tensions. Thanks to the careful sizing and traditional method of sand casting by hand, the cast-iron frame also enhances the sound.

STRINGS

Made from quality piano wire with high tensile strength and valuable copper wire from Germany, the strings have been calculated to maximize string length with a balanced register, harmonious partials and excellent tuning stability.

C. Bechstein agraffes in bass and the middle range, capo d'astro with duplex strings in the treble section, duplex scaling in the rear middle and treble section.

DUPLEX SYSTEM ②

Resonating duplex strings enrich the color and vibrancy of the tone. The system comprises the front duplex strings at a defined angle to the speaking length for a clear, colorful sound, as well as the rear duplex strings that enrich the harmonic overtones of the strings, mainly tuned in fifths and octaves.

SOUNDBOARD

The soundboard and ribs are made from selected, fine-grained European mountain spruce, which is stored for years and dried carefully. The bridges consist of **solid European beech with European beech caps**. The board has an **even thickness of 8 mm**. The ribs are not tapered at the edges until they have been glued onto the soundboard. The back frame and outer rim are fully glued and stored for months before the soundboard is glued on.

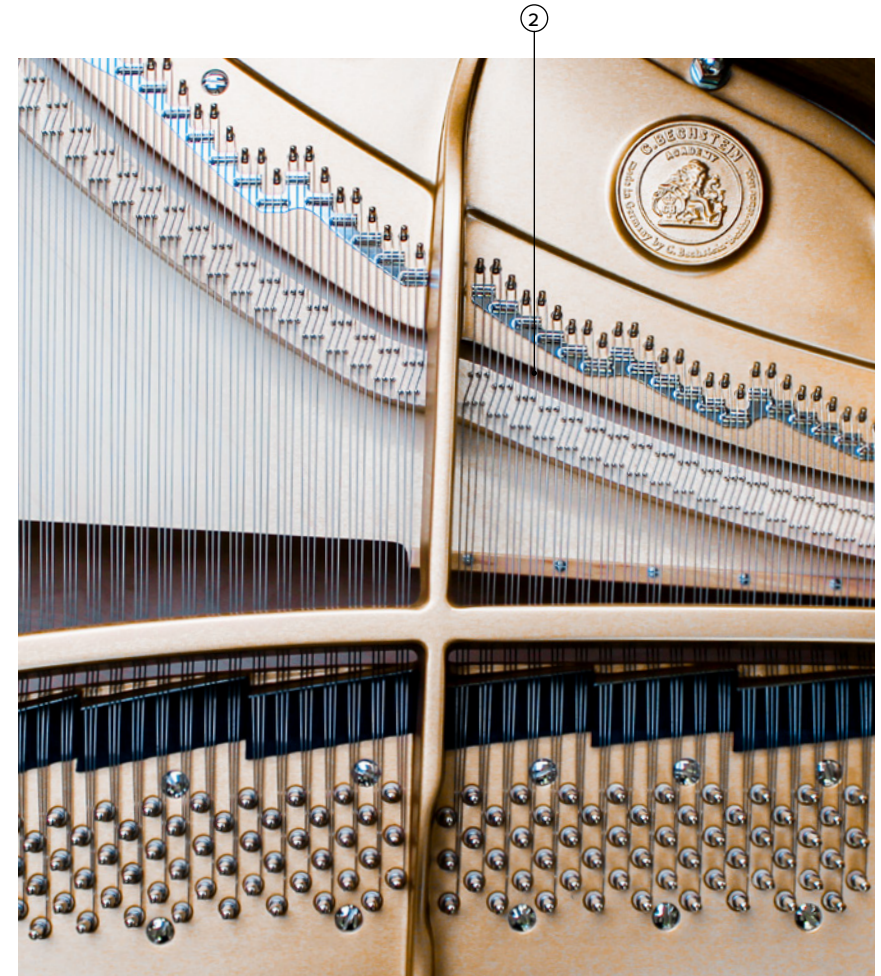



– ARTISANS – C. BECHSTEIN MANUFACTORY SEIFENHERSDORF –

Academy A 228 | Action

C. BECHSTEIN DYNAMIC TOUCH DESIGN

Developed in-house, the highly reliable C. Bechstein actions allow perfect control and execution in every position of the key movement and offer quick repetition as well as a pleasant and even touch. Every key is balanced individually.

KEYBOARD

A quality keyboard made of solid spruce keys, man-made white key tops with a **pleasant grip** and ebony sharps. Precise key movements with high-quality, wear-resistant bushing felt. Adjustable glide bolts support the balance rail. Precise and perfectly adjustable keyboard guidance mechanism in the cheek block.

C. BECHSTEIN ACTION ③

All components are designed, specified, selected, inspected and calibrated for precise and reliable function and durability. Strict selection and testing of all materials with regard to density, durability and gliding properties guarantee a reliable action at all times. **Traditional action frame with wooden rails.**

C. BECHSTEIN CONNECT

High-resolution, contactless infrared sensors record the piano piece, convert it to MIDI and make it available via Bluetooth. The original touch of the acoustic instrument is maintained.

C. BECHSTEIN HAMMER HEADS

Developed and produced in-house, C. Bechstein hammer heads ④ are a significant and consistent factor in the unique sound of the C. Bechstein Academy line – made with the highest-quality elastic felt and **mahogany** mouldings. The intricate, multi-stage process of voicing is **performed to C. Bechstein quality standards.**

PEDALS

3 pedals: Piano (una corda), sostenuto and forte (damper)

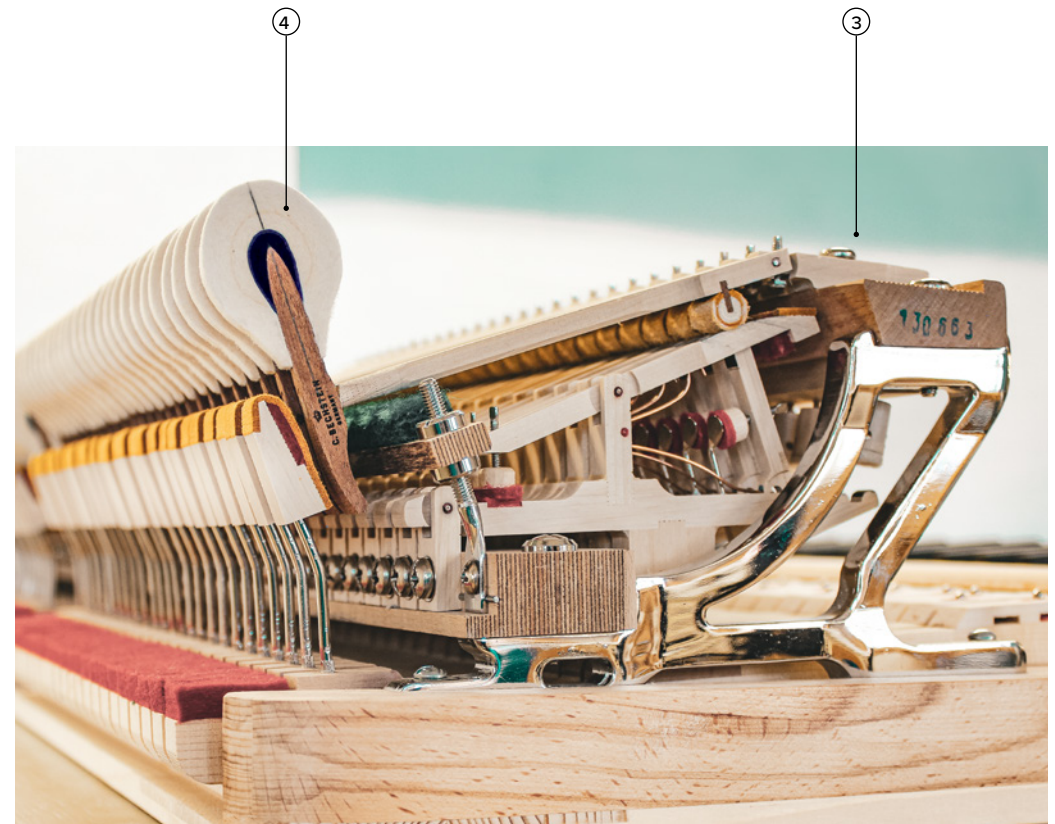



LE ARTISANS - C. BECHSTEIN MANUFACTORY SEIFENHEHERSDORF -

Academy A 228 | C. Bechstein Digital Systems

C. Bechstein Connect & Connect Pro

C. Bechstein Connect is a digital component for an acoustic instrument. While playing the piano, the system scans the keyboard and pedals of the instrument in high resolution and converts the data into MIDI, a universal musical instrument language. It connects to the popular apps via Bluetooth. The original touch of the acoustic instrument is maintained.

BLUETOOTH-MIDI

Connect smartphones, tablets or notebooks via Bluetooth to C. Bechstein Connect and popular apps for learning, playing or composing music.

SENSOR TECHNOLOGY ①

Optical sensors record the most subtle nuances in the movements of keys and pedals without making contact, providing flawless digital control over dynamics, articulation and agogic accents. Infrared sensors perform more than 200,000 measurements per second and calculate key velocity every 400 microseconds.

CONNECT PRO

The USB-C interface built into the C. Bechstein Connect Pro provides a wired connection with minimum latency for professional recordings in a studio.

Paired with the installation of the C. Bechstein hammer stop rail, which is configured for each individual instrument model, the instrument becomes a master keyboard.

POSSIBLE APPLICATIONS ②

MUSIC PRODUCTION

C. Bechstein Connect is compatible with popular DAW solutions such as Logic, Ableton and Cubase, making it easy to record piano pieces and produce music with plugins, loops and samples.

MUSICAL NOTATION

C. Bechstein Connect is compatible with notation software including Sibelius, Dorico and Finale, for notation in real time.

DIGITAL MUSIC LESSONS

C. Bechstein Connect and the all-in-one platform for digital music lessons doozoo (by C. Bechstein) are made for each other. In conjunction with C. Bechstein Connect, doozoo visualizes the notes played in a chord diagram or on the integrated virtual piano.

SOFTWARE INSTRUMENTS

Sample databases such as the Vienna Symphonic Library or virtual instruments like Pianoteq provide thousands of sounds for the piano.

The C. Bechstein Digital Grand Library sets new standards in the world of digital grand pianos.

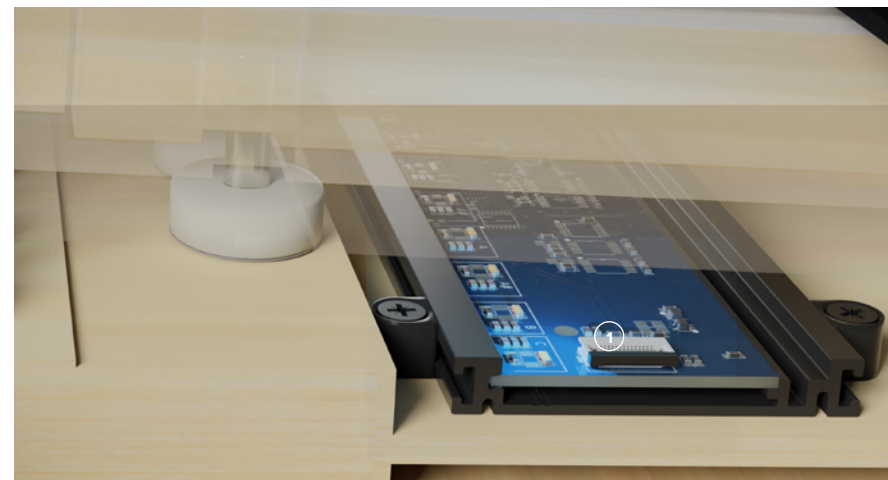

Academy A 228 | Digital extensions (optional)

VARIO duet – Silent-System

Das VARIO duet ③ adds a silent mode ④ and sound generation to C. Bechstein Connect. The sound module has two headphone outputs and high-fidelity Audio I/O.

OPERATION ⑤

Easy to operate with a single button. The built-in USB-C interface provides cutting-edge connectivity and recharges connected devices at high speeds of up to 45 W.

HAMMER STOP RAIL ⑥

The rail stops the hammers just before they touch the strings and mutes the acoustic piano. The original touch and the precise, controllable key strikes are maintained.

THE VARIO APP ⑦

The VARIO app for iOS /iPadOS and Android is the set-up and control centre for the VARIO digital system.

HEADPHONES ⑧

C. Bechstein headphones were developed especially for the VARIO silent systems. Their high fidelity and optimal wearing comfort are their hallmarks.

SOUND

The digital sound of the C. Bechstein Concert D-282 delivers a vast dynamic range and a remarkably sophisticated sound spectrum. Fully orchestral and clear across all registers for maximum artistic expressiveness.



Academy A 228 | Technical data

DIMENSIONS, WEIGHTS, COLORS

Dimensions (L × W × H) 229.5 cm | 7' 6" × 159 cm | 5' 3" × 102.5 cm | 3' 4"

Leg room 62 cm | 24.4"

Net weight 418 kg | 922 lbs

Designs Black, white; other finishes and veneers available on request

ACOUSTIC ASSEMBLY

Soundboard

Material Selected European mountain spruce

Tapering 8 mm

Ribs

Number 15

Material Selected European mountain spruce

Tapering After gluing the ribs to the soundboard

Bridge

Bridge body Solid Beech

Bridge cap Solid Beech

Rim beams

Number 4

Material Rim beams of solid pine, triple laminated

Dimensions 70 cm × 127 cm

Belly rail Lower vertical part made of solid beech, upper horizontal part made of solid pine with soundboard support made of solid beech

Rim Solid beech

Connection between beams & rim Diagonal dowels

Position of plate bolts Centered in the rim beams

Pinblock C. Bechstein pin block with three cross-laminated, solid hard maple layers, outer layers made from cross-laminated sheets of beech veneer

Tuning pins Nickle-plated steel, 6.9 mm × 64 mm

Cast-iron frame Sand-cast grey iron, drilled and milled with CNC technology

Bass/Middle/Treble 1/Treble 2 20/32/18/18

Agraffes

Material Brass

Number of bass 20

Number of middle length 32

Treble Capo d'astro

Longest tenor string 1,580 mm

Front duplex Both treble sections

Rear duplex Treble and upper middle section

Bell no bell

Academy A 228 | Technical data

ACTION

White keytops Man-made white keytops

Black keytops Ebony

Key material Spruce; with stable felt bushings treated for minimal friction and wear resistance

Total length Key 1 574 mm

Total length Key 88 524 mm

Key 1 levers: front/rear 287.5/148.5 mm

Key 88 levers: front/rear 263.5/132.5 mm

Key frame Spruce with Maple inlay for firm fixation of pins

Key bed Stable and climate resistant multilayer wood

Keyboard guidance Precise and perfectly adjustable keyboard guidance mechanism in the cheek block

Action

Frame Traditional action with wooden rails

Parts Hornbeam

Down weight Bass: 54 g | Middle: 52 g | Treble: 50 g (+/- 2g)

Up weight Bass: 23 g | Middle: 25.5 g | Treble: 28 g (+/- 2g)

3 pedals Piano (Una Corda), Sostenuto, Forte (Dampers)

HAMMERHEADS

Manufacturer C. Bechstein Pianofortemanufaktur, Seifhennersdorf, Saxony, Germany

Core wood type Mahogany

MUSIC STAND

Positions tiltable in 8 angles

LID

Lid support / lid positions 2-piece, fully or half open lid

FALLBOARD

Soft close Softclose fallboard

Lock Lock for fallboard and lid

CASTERS

Single/Double wheel, brake Double wheel castor, front casters with brake

Diameter 48 mm

MANUFACTURER

Manufacturer C. Bechstein Pianofortemanufaktur, Seifhennersdorf, Saxony, Germany

Quality control Quality control by C. Bechstein master piano makers and concert technicians

Warranty 5 years manufacturers warranty by C. Bechstein, Germany

**Established by
Carl Bechstein in Berlin
in 1853 and beloved
by the most significant
artists ever since, from
Franz Liszt to Elton John.**

C. Bechstein is one of the very few names to be synonymous with outstanding grand and upright pianos the world over. Established by Carl Bechstein in Berlin in 1853, the pianoforte workshop quickly grew into a company which, to this day, enjoys a stellar reputation in the eyes of musicians.

The quality of its pianos was valued by Franz Liszt, Richard Wagner and Hans von Bülow, as well as by Wilhelm Backhaus, Sergei Rachmaninoff and Leonard Bernstein.

The name “C. Bechstein” can even be found on the pages of pop and rock history. The greatest hits by Elton John, the Beatles, Queen and countless other artists were crafted on C. Bechstein pianos. This is due in no small part to the founder’s passion for development, to which the company remains beholden to this day.

Relentless research and development, supreme vertical integration down to the smallest details and continuous expert training mean our pianos represent the absolute pinnacle of piano construction — always in the spirit of C. Bechstein’s famed touch and sound.

**Fascinating
sound. Loved
and adored ever
since it was
developed by the
visionary master
piano maker
Carl Bechstein.**

PUBLISHING DETAILS

© 2025 C. Bechstein Sales & Service GmbH
Kantstraße 17 | 10623 Berlin
Phone: +49 (0)30 226 05 59 59
welcome@bechstein.com

www.bechstein.com

 bechstein.official

 bechstein.official

 C. Bechstein

Pictures: Pascal Bünning, C. Bechstein

C. Bechstein reserves the right to make technical changes to all models with regard to acoustic construction, cabinet, leg and lyre design and finishes.